



Email:

contact@sbel.ma

Numéro Téléphone:

(+212) 525 049 565

(+212) 665 039 556



Articulating Booms

GTHZ120 / GTHZ170 / GTHZ170C / HZ210AI

The World of Hangcha
SINCE 1956



Articulating Booms

This machine has articulation boom which can work across the obstacle. It can carry two people and some tools in the basket. The machine allows you to operate it in limited place with narrow design and small radius turning system. You can operate the machine from basket or base control, so when you want to move it, you do not need to go down the machine. Multi-motion control allows you to operate several actions simultaneously. With this machine, you can do work more efficient and comfortable.

Easy/
Efficiency/
Economy



Standard specification

- / Electrical battery traction
- / Negative brakes
- / Lifting brakes
- / Hour meter
- / Warning buzzer in the basket
- / 220V predisposal
- / Voltage indicator
- / Safety manual pump
- / Bus CAN technology
- / Diagnostic help integrated
- / Dual electrical motors
- / No marking tires
- / Anti-roll system
- / Integrated charger

Options

- / Working lights
- / Flashing light(all motion alarm)
- / Buzzer
- / Air predisposal
- / Electrical plug 220V
- / Over-load sensor system

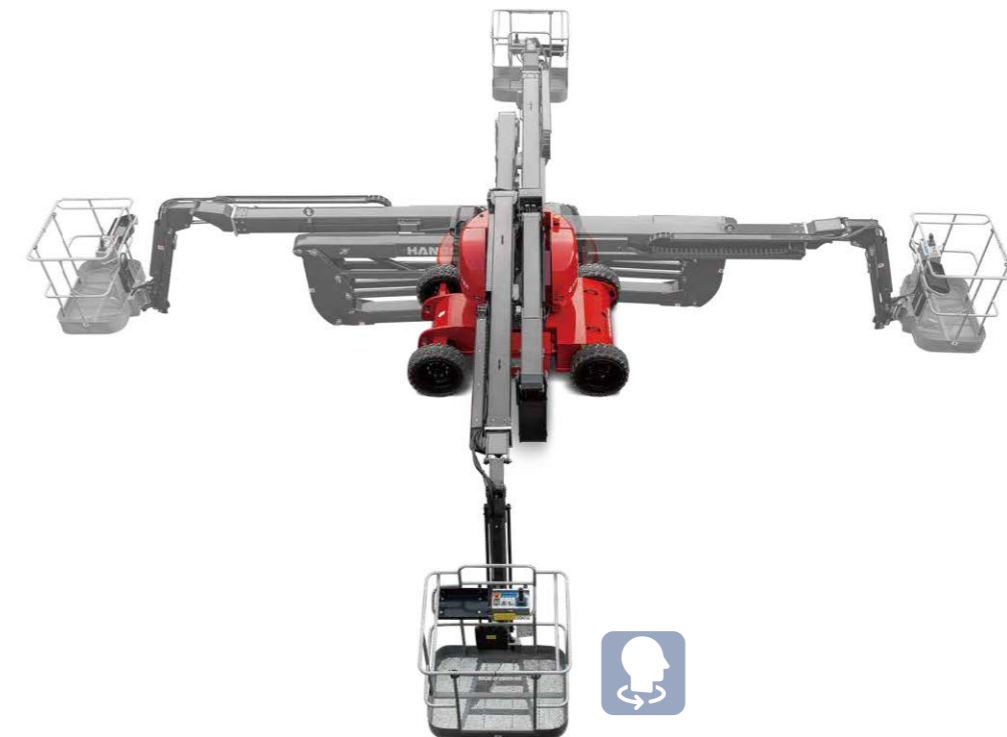

1 Basket: can be rotated left and right at an Angle of 140°



2 Base control box: the control box can be used to control each action of the device, easy to understand



3 Tires: foam-filled tires with good off-road performance



4 Basket control box: each action of the device can be controlled through the control box to quickly reach the working area, and the control is simple and easy to understand



5 Standard tracking battery: Reduce 40% of the charge time, raise 50% of the life time

Features

- / Increase the ground clearance to improve passability;
- / This platform is provided with rough terrain tires, which are more suitable for working outside;
- / The driving speed is 6.1km/h.
- / Climbing performance is increased to 30%;
- / Integrated design of motor and reducer. The motor controls the reducer to brake, reducing the impact of braking and improving the user's comfort.
- / Potentiometer is installed on the equipment, so that the left and right wheels have different speed when steering, so the steering is more stable.
- / The drive motor is AC motor.



GTHZ170C

GTHZ170

GTHZ120

Articulating Booms

		HANGCHA GROUP CO.,LTD.		
		GTHZ120	GTHZ170	GTHZ170C
1	Manufacturer			
2	Model	GTHZ120	GTHZ170	GTHZ170C
3	Working height	m	11.95	16.75
4	Platform height	m	9.95	14.75
5	Horizontal height	m	7.00	9.43
6	Up and over height	m	4.77	7.16
7	Length	m	5.48	6.84
8	Length (storage)	m	3.74	5.4
9	Wheel base	m	1.65	2
10	Width	m	1.22	1.75
11	Height	m	1.99	2.09
12	Height (storage)	m	2.16	2.09
13	Basket size	m	1.20x0.77	1.20x0.77
14	Turning radius inside	m	1.55	2.0
15	Turning radius outside	m	3.25	4.30
16	Turning radius outside (basket)	m	3.34	5.6
17	Ground Clearance	m	0.10	0.15
18	Capacity	kg	200	200
19	Jib movement		±70°	±70°
20	Basket rotation		140°	140°
21	Turret rotation		350°	355°
22	Drive speed	km/h	6.00	4.50
23	Working speed	km/h	0.60	0.60
24	Gradeability	%	25%	22%
25	Maxi slope acceptable	%	3° or 5%	3° or 5%
26	Tires	m	0.60x0.19	0.60x0.19
27	Wheel steer		2	2
28	Wheel drive		2	2
29	Batteries (C5)	V/Ah	300Ah,2x24V	300Ah,2x24V
30	Weight	kg	6550	7030

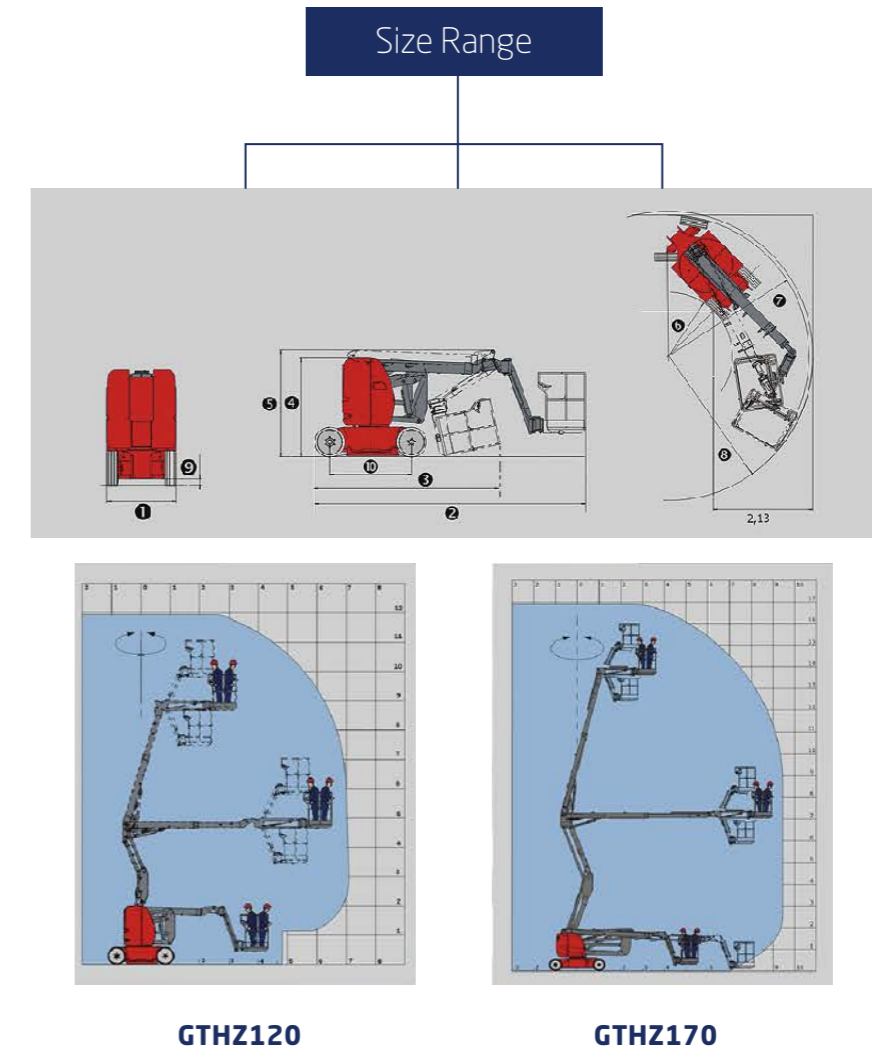

GTHZ120

GTHZ170

Your reliable partner for outdoor construction and industrial applications, the Hangcha first rough terrain articulating boom lift with capabilities provides lifting versatility with a combination of up, out and over positioning capabilities.

Safe and reliable

- / Swing shaft design, good off-road performance, keep stable when crossing potholes;
- / Middle arm frame, compact structure, safe and stable.
- / Control system redundancy design, cylinder to the top buffer design, the boom movement is smooth, comfortable operation;
- / All key parts adopt well-known brands in the industry, with high reliability;
- / Four-wheel electromagnetic braking;

Energy saving and efficient

- / Standard lithium iron phosphate battery, energy saving and environmental protection, short charging time, long life;
- / Gravity drop hydraulic system, energy saving, strong endurance;
- / The whole vehicle with ac system, high efficiency;
- / Using proportional valve, stepless speed regulation, fast response, stable operation;
- / Equipped with large size platform and three doors design.

Intelligent

- / Cloud intelligent module, which can realize the remote management of vehicles.

Storage

- / Can be transported by container.



HZ210AI

HZ210AI Specification

1	Manufacturer	HANGCHA GROUP CO.,LTD.
2	Max. platform height	18.80m
3	Max. working height	20.80m
4	Max. up and over height	8.28m
5	Max.horizontal height	11.45m
6	Max.horizontal working height	11.95m
7	Overall length	8.63m
8	Overall width	2.49m
9	Width(storage, change the tyres for container)	2.3m
10	Overall height	2.43m
11	Wheel base	2.5m
12	Grand clearance	0.31m
13	Platform size	2.2m×0.8m×1.1m
14	Tire	315/55 D20
15	Capacity	255kg(350kg)
16	Operators	2
17	Max. Manual force	400N
18	Max.driving speed (transport mode)	6.1km/h
19	Max. driving speed(working mode)	0.8km/h
20	Mini. turnig radius inside	2.05m
21	Gradeability	40%
22	Max. slope angle	5°
23	Turret rotation	360°continually
24	Tail swing	0.31m
25	Max. wind speed	12.5m/s
26	Basket rotation	180°
27	Jib movement	70°/-60°
28	Wheel drive	4WD×2WS
29	Drive motor	6kW
30	Hydraulic motor	3.3kW
31	Oil tank	60L
32	Lithium battery	48V, 375Ah
33	Electrical system voltage	48V
34	Control system voltage	12V
35	Weight	9300kg
36	Tire load	5000kg

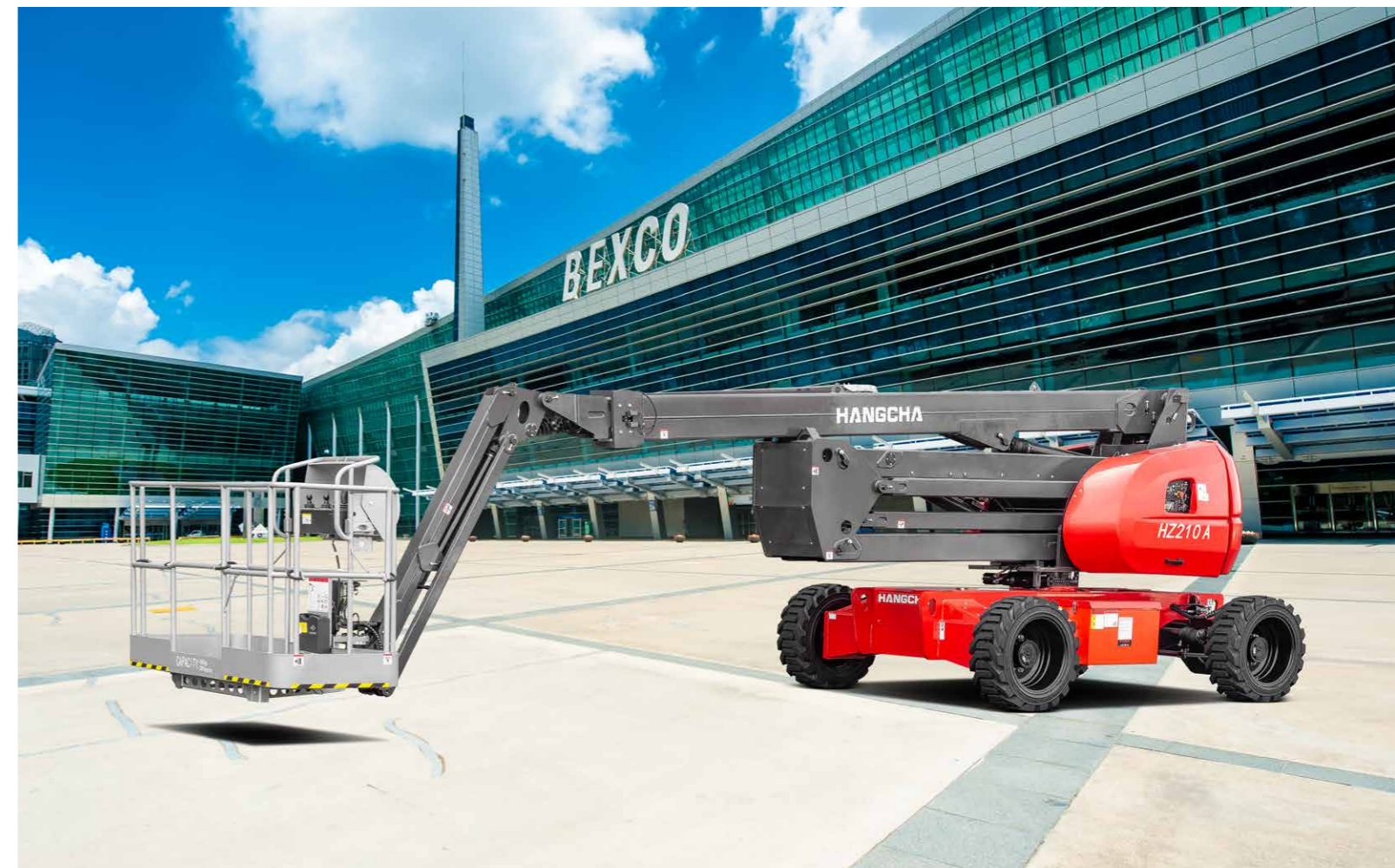

Vertical mast lift Specification

01	Manufacturer		HANGCHA GROUP CO.,LTD.
02	Model		HV110D
03	Maxi.working height	m	11.22
04	Maxi.platform height	m	9.22
05	Up and over height	m	7.89
06	Horizontal height	m	3
07	Jib movement	°	+70 /-60
08	Turret rotation	°	345
09	Capacity	kg	210
10	Maximum number of workers	m	2/1
11	Platform dimensions	m	0.93*0.65
12	Width	m	1
13	Length	m	2.65
14	Height	m	2
15	Turning radius(inside)	m	0.23
16	Turning radius(outside)	m	1.65
17	Ground distance	m	0.06
18	Wheelbase	m	1.22
19	Maxi. Travelling speed	km/h	4.5
20	Mini. Travelling speed	km/h	0.5
21	Maxi slop rating	%	25
22	Maximum allowable inclination	°	2.5
23	Tyre	mm	381*127
24	Weight	kg	2930
25	Charger	V/A	24/30
26	Battery	V/ah	24/300

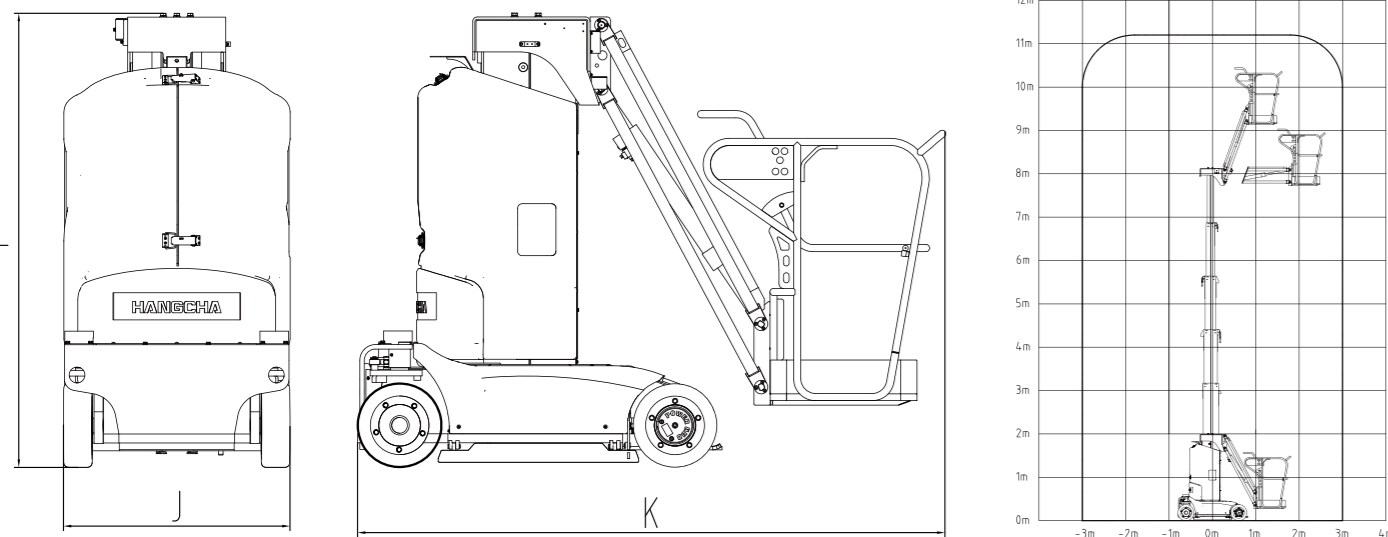

Vertical mast lift

The World of Hangcha
SINCE 1956



Vertical mast lift

The HANGCHA HV110D is a jib machine that offers outreach capability to get virtually any job done. A 130° rotating jib and 345° non-continuous hydraulic turntable allows for exceptional range of motion and precise positioning. These capabilities combined with the efficient electric drive motors and a low machine weight make the HANGCHA HV110D lift the solution for hard-to-reach jobsite needs.

It has the characteristics of compact body size, small turning radius, good handling performance and strong endurance. It is mainly used in warehouse, exhibition hall, aircraft maintenance, mechanical equipment installation, equipment maintenance and other fields.



Anti-overturning system

/ When the machine raises, this system will open automatically, to protect the machine from overturning while walking at un-leveling ground.

Safety

/ Alloy steel axis, to make sure the safety, reliable and efficient.

Internal charger

/ You can charge the battery directly, do not need to remove it from machine.

The working scope

/ It can go to the working area rapidly trough lifting, lowering, travelling forward and backward, turret turning, etc.

Self-leveling sensor

/ When the degree is more than 2.5°, it will alarm.

The proportional control system

/ Control the speed of traveling, lifting and turret turning as you need.

The turning radius

/ It can work in a very compact area.

LED display

/ Easy for troubleshooting.



CAN BUS control system

/ The machine is equipped with CAN BUS control system, it makes the electrical system simple, reliable, easy maintenance and troubleshooting.



Options

/ Basket socket device
/ Work lamp
/ Anti-collision sensor

Standard Specification

/ The proportional joystick
/ The anti-overturning system
/ Easy access
/ Self-propelled
/ No marking tyre
/ 4X2 drive
/ Automatic break
/ Emergency lower system
/ Flashing light
/ Emergency stop system
/ Explosion proof valve
/ Fault diagnosis
/ Self-leveling sensor
/ 345°non-continuous turret turning
/ Buzzer
/ Horn
/ Swing cover

